

ONLINE INDUSTRIAL PROCESS BROADCAST AND CONTROL BASED ON IP AND SERIAL NETWORKS

Nicolae PARASCHIV*, Alexandru POPA**, Cristina POPA*

*Petroleum University of Ploiesti – Romania

**Institute of Petroleum Engineering Clausthal - Germany

Abstract: The Internet network in conjunction with a strong security policy can be an ideal online broadcast system for the industrial processes monitoring and control. Because the distributed controllers are connected through industrial serial connection, the network between controllers cannot be extended very much. The problem appears when the plant is away and cannot be accessed via a serial connection. For administrative and control purposes the serial network can be interconnected with an IP network. In this case the operator can be anywhere in the world and can interact via an interface with the process. This paper will describe flow process remote controlled using a mixture of two communication technologies: RS485 and TCP/IP. The junction between these technologies is transparent and the operator is able to monitor the process using an interface console.

Keywords: control, fieldbus, industrial network, Ethernet, serial-communication, security.

1. INTRODUCTION

In the last 10 years the fieldbuses have changed in the point-to-point analog or hybrid communication systems. These buses incorporate the field devices themselves as part of the control network supporting bidirectional communications with verification of all the parameters at both ends of the network.

The next generation of field devices and networks are based on Ethernet technology. Most experts agree Ethernet is the high-speed industrial communications medium of the future, no matter whether it platforms on copper cable, fiber, or wireless media.

The use of Ethernet in industrial and plant environments has grown in the last few years. Industrial users have now a wide range of options

when designing and implementing plant-level Ethernet networks.

The changing of the legacy fieldbuses networks into Ethernet networks can cause problems related to the interconnectivity and costs. The Ethernet networks provide a high level of reliability, good transfer rate and usual IT personal for maintenance.

The plant Ethernet network can carry the information between the control room and field controllers, transducers and actuators using interfaces converters. Due the IP protocols, the plant communication can be secured and audited. The process can be broadcasted and controlled anywhere in the world.

The implementation of a reliable system implies communication and synchronization between the

components of the system (Gardner, J. 2007). Tackling in the account the issues of the controlled processes the Ethernet network requirements will be accomplished by: speed of communication, fault tolerance, interoperability with different industrial protocols, immunity to external disturbances (electrical, thermal, humidity), capability to be managed by IT professionals.

This paper presents an approach to adapt a serial RS485 network to a cabled Ethernet network, and to integrate then in a system able to interact directly with a process supervisor. The communication between process and user become transparent and consistent. This system provides the opportunity to interact remote with the plant.

2. INTERCONNECTING THE NETWORKS

RS485 is serial communication methods for computers and devices. RS485 is the most versatile communication standard in the standard series defined by the EIA. That is why RS485 is currently a widely used communication interface in data acquisition and control applications where multiple nodes communicate with each other.

RS485 can be used to communicate with remote devices at distances up to 1200m (and at speeds of up to 100Kbps at this distance).

EIA-485 (formerly RS-485 or RS485) is an OSI Model physical layer electrical specification of a two-wire, half-duplex, multipoint serial connection. The standard specifies a differential form of signaling. The difference between the wires' voltages is what conveys the data. One polarity of voltage indicates a logic 1 level, the reverse polarity indicates logic 0. The difference of potential must be at least 0.2 volts for valid operation, but any applied voltages between +12 V and -7 volts will allow correct operation of the receiver.

EIA-485 only specifies electrical characteristics of the driver and the receiver. It does not specify or recommend any data protocol. EIA-485 enables the configuration of inexpensive local networks and multidrop communications links. It offers high data transmission speeds (35 Mbit/s up to 10 m and 100 kbit/s at 1200 m). Since it uses a differential balanced line over twisted pair (like EIA-422), it can span relatively large distances (up to 4000 feet or just over 1200 meters).

The recommended arrangement of the wires is as a connected series of point-to-point (multidropped) nodes, a line or bus, not a star, ring, or multiply-

connected network. Ideally, the two ends of the cable will have a termination resistor connected across the two wires. Without termination resistors, reflections of fast driver edges can cause multiple data edges that can cause data corruption. Termination resistors also reduce electrical noise sensitivity due to the lower impedance, and bias resistors (see below) are required. The value of each termination resistor should be equal to the cable impedance (typically, 120 ohms for twisted pairs). Star and ring topologies are not recommended because of signal reflections or excessively low or high termination impedance.

Somewhere along the set of wires, powered resistors are established to bias each data line/wire when the lines are not being driven by any device. This way, the lines will be biased to known voltages and nodes will not interpret the noise from undriven lines as actual data; without biasing resistors, the data lines float in such a way that electrical noise sensitivity is greatest when all device stations are silent or unpowered.

Often in a master-slave arrangement when one device dubbed "the master" initiates all communication activity, the master device itself provides the bias and not the slave devices. In this configuration, the master device is typically centrally located along the set of EIA-485 wires, so it would be two slave devices located at the physical end of the wires that would provide the termination. The master device would provide termination if it itself was located at a physical end of the wires, but that is often a bad design as the master would be better located at a halfway point between the slave devices. Note that it is not a good idea to apply the bias at multiple node locations, because, by doing so, the effective bias resistance is lowered, which could possibly cause a violation of the EIA-485 specification and cause communications to malfunction. By keeping the biasing with the master, slave device design is simplified and this situation is avoided.

Network topology is probably the reason why RS485 is now the favorite of the four mentioned interfaces in data acquisition and control applications. RS485 is the only of the interfaces capable of internetworking multiple transmitters and receivers in the same network. When using the default RS485 receivers with an input resistance of 12 k Ω it is possible to connect 32 devices to the network. Currently available high-resistance RS485 inputs allow this number to be expanded to 256. RS485 repeaters are also available which make it possible to increase the number of nodes to several thousands, spanning multiple kilometers. And that with an interface which does not require intelligent network hardware: the implementation on the software side is not much more difficult than with RS232. It is the reason why

RS485 is so popular with computers, PLCs, micro controllers and intelligent sensors in scientific and technical applications (Soltero, M., Zhang, J., Cockrill, C. 1994).

The term Ethernet refers to the family of local-area network (LAN) products covered by the IEEE 802.3 standard that defines what is commonly known as the CSMA/CD protocol. Three data rates are currently defined for operation over optical fiber and twisted-pair cables:

- 10 Mbps—10Base-T Ethernet
- 100 Mbps—Fast Ethernet
- 1000 Mbps—Gigabit Ethernet

10-Gigabit Ethernet is under development and will likely be published as the IEEE 802.3ae supplement to the IEEE 802.3 base standard in late 2001 or early 2002.

Other technologies and protocols have been touted as likely replacements, but the market has spoken. Ethernet has survived as the major LAN technology (it is currently used for approximately 85 percent of the world's LAN-connected PCs and workstations) because its protocol has the following characteristics:

- Is easy to understand, implement, manage, and maintain
- Allows low-cost network implementations
- Provides extensive topological flexibility for network installation
- Guarantees successful interconnection and operation of standards-compliant products, regardless of manufacturer

The original Ethernet was developed as an experimental coaxial cable network in the 1970s by Xerox Corporation to operate with a data rate of 3 Mbps using a carrier sense multiple access collision detect (CSMA/CD) protocol for LANs with sporadic but occasionally heavy traffic requirements. Success with that project attracted early attention and led to the 1980 joint development of the 10-Mbps Ethernet Version 1.0 specification by the three-company consortium: Digital Equipment Corporation, Intel Corporation, and Xerox Corporation.

The original IEEE 802.3 standard was based on, and was very similar to, the Ethernet Version 1.0 specification. The draft standard was approved by the 802.3 working group in 1983 and was subsequently published as an official standard in 1985 (ANSI/IEEE Std. 802.3-1985). Since then, a number of supplements to the standard have been defined to take advantage of improvements in the technologies and to support additional network media and higher data rate capabilities, plus several new optional network access control features.

Throughout the rest of this chapter, the terms Ethernet and 802.3 will refer exclusively to network implementations compatible with the IEEE 802.3 standard.

Ethernet LANs consist of network nodes and interconnecting media. The network nodes fall into two major classes:

- Data terminal equipment (DTE)—Devices that are either the source or the destination of data frames. DTEs are typically devices such as PCs, workstations, file servers, or print servers that, as a group, are all often referred to as end stations.
- Data communication equipment (DCE)—Intermediate network devices that receive and forward frames across the network. DCEs may be either standalone devices such as repeaters, network switches, and routers, or communications interface units such as interface cards and modems.

Throughout this chapter, standalone intermediate network devices will be referred to as either intermediate nodes or DCEs. Network interface cards will be referred to as NICs.

The current Ethernet media options include two general types of copper cable: unshielded twisted-pair (UTP) and shielded twisted-pair (STP), plus several types of optical fiber cable.

Ethernet Network Topologies and Structures

LANs take on many topological configurations, but regardless of their size or complexity, all will be a combination of only three basic interconnection structures or network building blocks.

The simplest structure is the point-to-point interconnection, shown in Figure 7-1. Only two network units are involved, and the connection may be DTE-to-DTE, DTE-to-DCE, or DCE-to-DCE. The cable in point-to-point interconnections is known as a network link. The maximum allowable length of the link depends on the type of cable and the transmission method that is used.

Converters from Ethernet to RS485 allow the PC to communicate with remote serial devices. By using "Repeaters" and "Multi-Repeaters" and converters very large RS485/Ethernet networks can be formed.

3. THE BROADCAST SYSTEM

The block schema of the system is presented in the figure 1. The system contains three main components: the process, the communication node

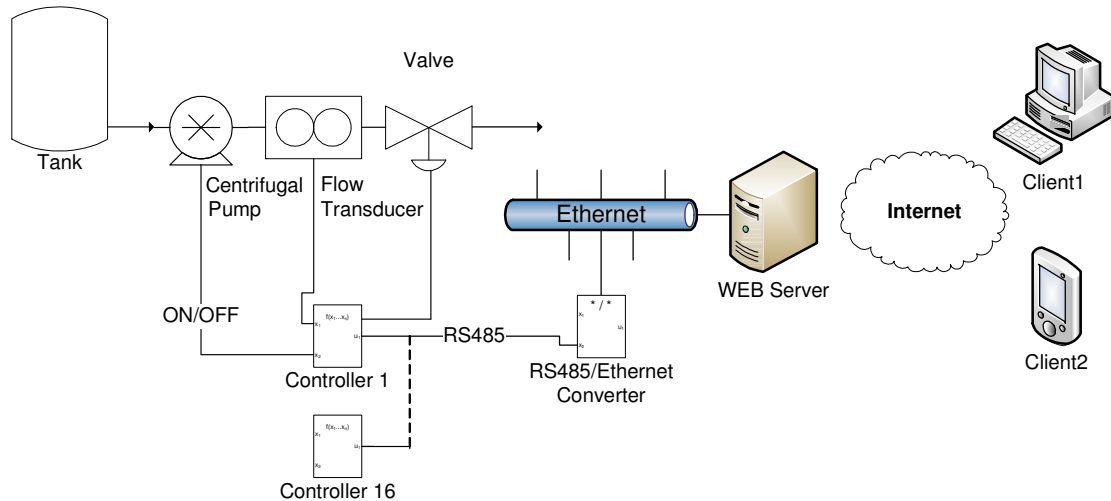

Fig.1. The block diagram of the broadcast system with networks junction point and the client-server subsystem.

The controller used in this system is Honeywell UDC 150R with Fuzzy Autotune. This is a PID Controller and has one input and three outputs. These outputs can be switched as analog or binary. The valve is connected to analog command and the pump is triggered by a digital output.

The flow process is controlled by the controller1. After the tank on the pipe are mounted a centrifugal pump, a flow transducer with diaphragm and a servovalve. The input read the signal from the flow transducer. The parameter for the controller can be set directly from the console or remote via the serial RS485 interface. The controller1 is connected on the field in a RS485 network as slave device with address 1.

Next are presented few parameters for the controller:
Input sample rate – four sample/second
Input resolution – 14 bits approximately
Communication – RS485
Two 4-digit displays and four tactile feedback keys
Power Consumption – 4W

The parameters of the controller are edited using specific commands. The commands have four forms:
Type1: L{N}??*
Type2: L{N}{P}{C}*
Type3: L{N}{P}#{DATA}*
Type2: L{N}{P}I*

Where all characters are in ASCII code and
L – is the start of message
{N} – is the slave controller address
{P} – is a character which identify the parameter to be interrogated/modified

{C} – is the command
{DATA} – is a string of numerical data in ASCII code
* – is the end of message

The network junction represents the middle part of the system. The two networks are joined using an RS485/Ethernet converter. The converter is a EP132X and can interface Ethernet with RS485 and RS232 serial communications. The device receives an IP address on the Ethernet side. Using an IP socket the device is switching the Ethernet in serial communication. In this case, RS485 is assigned to port 101. the converter provide a Web server in order to set the IP address, serial protocol parameters, the ports of the IP socket.

The commands for the controller are sent as plain text using the IP socket. After a valid command, the selected controller is responding to the request. In this case, the converter represents the physical master device and the WEB server from the figure 1 represents the logical master device. The WEB server is able to query the controllers in a transparent way without tacking in account the network protocols.

The junction between networks can be made on the field, tacking in account the maximum length of 1200m in the RS485 network. The Ethernet network can be cabled or wireless. New communication technologies have emerged that provide high-speed wireless Ethernet communications to field applications. Like all new technologies, there are many products that are capable, yet few that actually are applicable to the rigorous field conditions or even many industrial applications (Gardner, J. 2007).

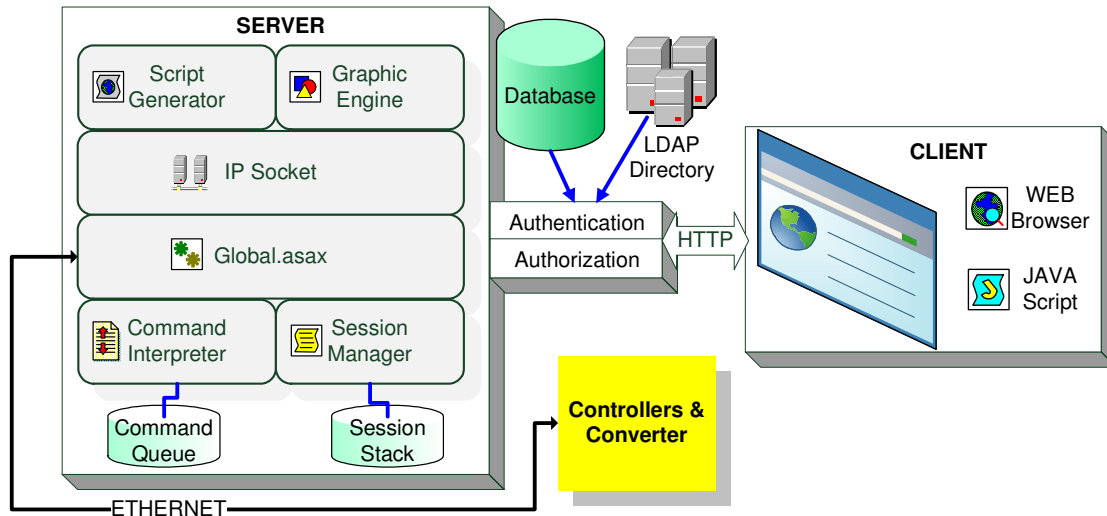

Fig. 2. The Distributed broadcast application with controller, server and Web browser

The downstream of the system is represented by the broadcast software. This software is able to record, to present and to change the process variables. The WEB server is an Active Server Page and is running over the .NET Framework 2.0 platform. The clients are represented by a Web browser.

Using the HTTP protocol, the clients are able to view the instant values and the history chart the supervised process. They can also modify the controllers parameters like PID coefficients, the set point and they can also send plain text commands for the controllers.

4. THE SURVEILLANCE SYSTEM

The software system has two main classical components: the client and the server. The schema of the software structure is presented in picture 2. The application is designed in the "n-tier" distributed model.

The server is a Windows 2003 Server with IIS 6.0 (Internet Information Services). The IP address of the server is accessible by Internet. For security reasons the converter is connected in the corporate intranet (has a private IP address).

The Global.asax class is the application class and is able to synchronize the clients requests whit the computing procedures.

The IP socket assures the communication between server and the network adapter respectively with

controller side. The socket is sending the commands on the port 101 and after that is listening for the answers.

The script generator insert JAVA Script in the HTML response. The script force the client browser to initiate regulate request to refresh the graphics and the instant values. The client page is not completely refreshed and just the variable components are reloaded. The script generator is adapting his output in order to match the client requirements.

The graphic engine is called with specific parameters by the client. These parameters allow to client to view a customized chart with specific series. The graphic is created just on the client demand and is packed in a jpg image.

The command interpreter translates the clients queries into commands accepted by the controller. This interpreter is also able to parse the controller response into global variable ready to use for calculation and display. The commend interpreter is connected with a commend queue were stored the commands who are waiting to be processed.

The session manager is used to audit the users access and activity as: logon and logoff time, client IP address, user name. These reports are available real-time just for users from the administrators group. At the logon every user is receiving a session ID. When a client browser refreshes the content (the chart or the instant values), the session manager is trigger. Because IIS is not able to delete the sessions just after en expiration period the

session manager can supervise the user activity and when this activity is not detected the user session is programmatically deleted. In this way, the administrator can be informed with a precision of 30 seconds about users connected in the system.

The authentication is made using the form authentication method. The user repository is represented by Access database or LDAP directory (for example Active Directory). The authorization is specified in Access Control List or in Web.config file.

At the end of this chain is connected the client. The client is represented by a Web Browser able to interpret Java Script (see figure 3).

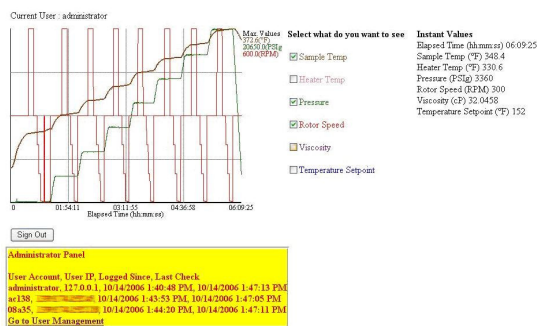

Fig.3. The client Web interface

On the client side are refreshed just the specific components and not the entire page. This strategy will reduce the traffic generated by a full refresh of the page and will avoid the security problems where the "meta refresh tag" is disabled. The administrator page shows also the user activities. The user can also choose to view multiple graphs in the same chart.

5. CONCLUSIONS

This paper is presenting an application for remote control and supervise of a multiple process, depending on the amount of the individual controllers. The engine of the application is designed to be interfaced with different measurement systems like LabView, DasyLab or read datastreams from sockets or files. The diversity of the network types cause no problem to the final user because of the transparency of the network parsers.

This implementation represent also a business solution allowing the broadcasts of a specific

laboratory processes to the clients or to distance learners. It is important when locking for new technology, and definitely before deploying any of them, that ensure they meet field installations requirements: temperature, humidity, electrical disturbances and chemicals.

The presented system is modular and is able to interact with the controllers from the Honeywell UDC 150R series. The network adapter is transparent for the broadcast mechanism and the server communicate with the controller like one usual IP device.

The Ethernet protocols represent a new way to collect and to transmit data in the industrial environment and the ultimate Ethernet network is represented by wireless technologies.

The paper (Baillieul, J., Antsaklis, P. 2007) consider the networked control systems research lies primarily at the intersection of three research areas: control systems, communication networks and information theory, and computer science. Networked control systems research can greatly benefit from theoretical developments in information theory and computer science.

These networked solutions are able to improve the integration of the new concepts for control networks based on intelligent agents.

REFERENCES

- Baillieul, J.; Antsaklis, P.J. (2007) *Control and Communication Challenges in Networked Real-Time Systems*, Page: 9-28, Proceedings IEEE – Technology of Networked Control Systems, Vol. 95
- Gardner, J. (2007). Converting serial networks to Ethernet communications. *Pipeline & gas journal*, **234**, 40-42.
- Sebestyen, Gh. (2006). *Informatică Industrială*, Editura Albastră, Cluj-Napoca
- Soltero, M., Zhang, J., Cockrill, C. (1994). 422 and 485 *Standards Overview and System Configurations Application Report SLLA070C*. Texas Instruments
- *** (2006). *Internetworking Technologies Handbook*, Cisco Systems
- *** EP132X User Manual
- *** Honeywell UDC 150R *Universal Digital Controller with Fuzzy Autotune Product Manual*